

Design Pressure = 150 PSI @ 120 °F  
 Min. Design Temperature = 20 °F @ 150 PSI  
 Hydrotest Pressure = 165 PSI

**150 PSI**  
 END PORT

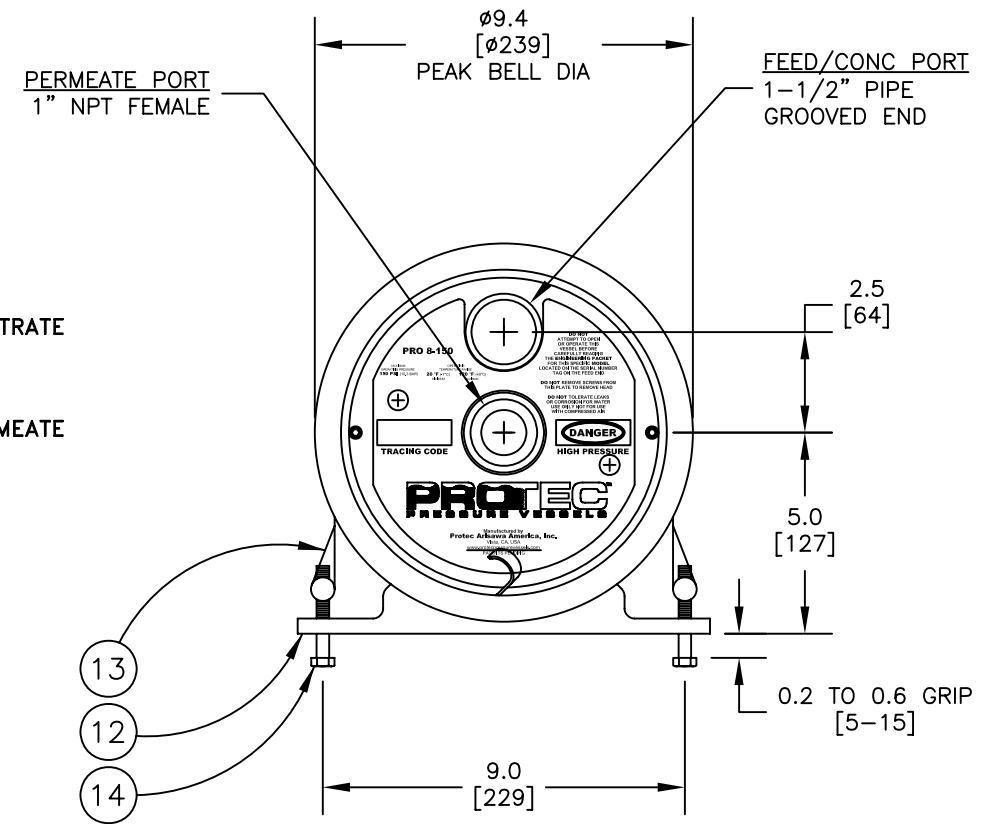
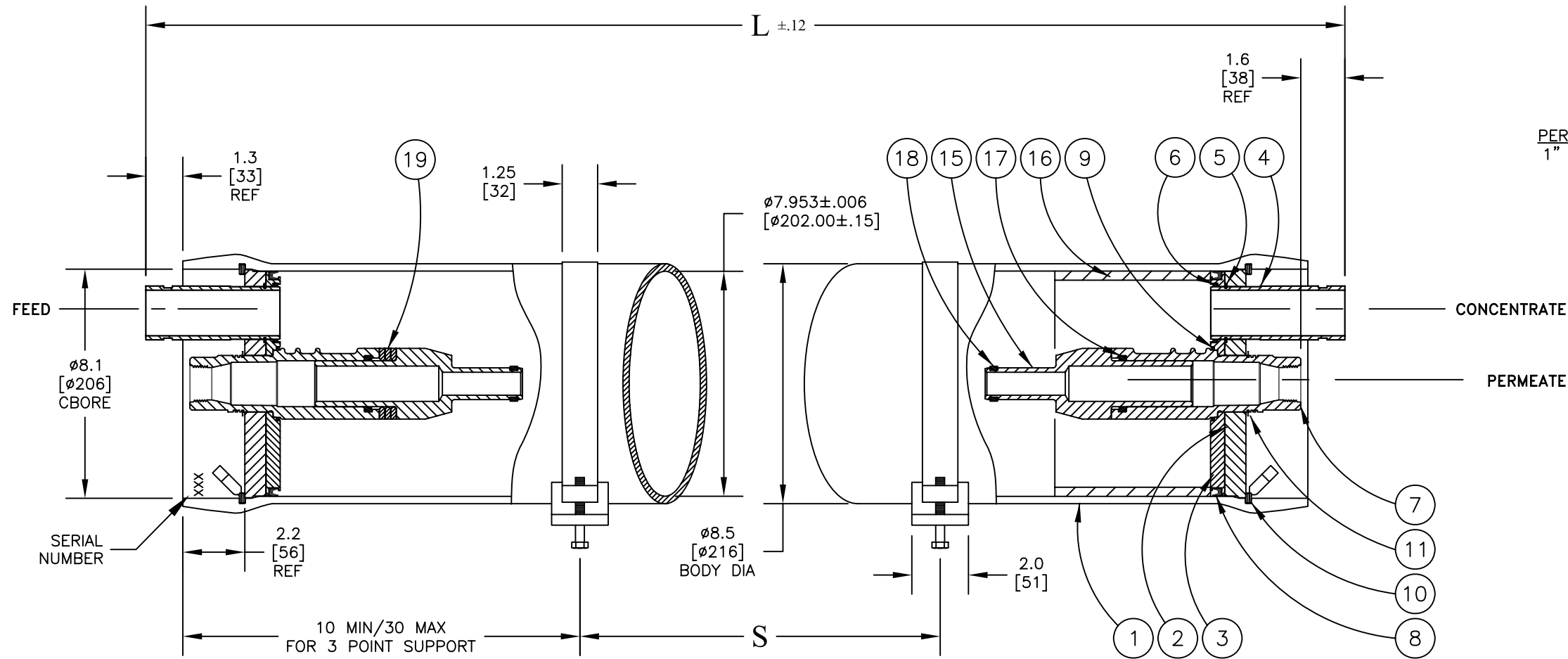

NOTE: STANDARD PARTS ARE SHOWN FOR REFERENCE ONLY  
 CHECK ORIGINAL ORDER FOR ORDERING SPARE PARTS

ITEM	QTY	P/N	DESCRIPTION	MATERIAL
1	1	4080001	Shell	Filament Wound, Epoxy FRP
2	2	4080027	Bearing Plate	6061-T6 Aluminum, SB-221
3	2	4080065-1	Sealing Plate	PVC Thermoplastic
4	2	4080100-1	Feed/Concentrate Port	Stainless Steel, 316, SA-312
5	2	6121187	Retaining Ring, F/C Port	Stainless Steel, 316
6	2	6184604-N	O-Ring Seal, F/C Port	Ethylene Propylene
7	2	4080289	Permeate Port	Noryl GFN2
8	2	6100442MK	Head Seal	Ethylene Propylene
9	2	6110229-N	Permeate Port Seal	Ethylene Propylene
10	2	4080320	Retaining Ring w/ Finger Pull	Stainless Steel, 316
11	2	6121200	Retaining Ring, Permeate Port	Stainless Steel, 316
12	2*	4080173	Support Saddle	TPR
13	2	4080137	Strap Assembly	Stainless Steel, 316
14	4	6150001	Strap Screw	Stainless Steel, 316
15	2	A/R	Adapter	PVC Thermoplastic
16	1	4080043	Thrust Ring	PVC Thermoplastic
17	2	6110326-N	Adapter Seal	Ethylene Propylene
18	A/R	A/R	PWT Seal	Ethylene Propylene
19	3	4080062-4	Shim, Adapter	Noryl GFN2

\*3 each with shell length -7 and longer

**NOTES:**

- DIMENSIONS IN INCHES (MM APPROX.)
- FOR REFERENCE ONLY, NOT FOR CONSTRUCTION UNLESS CERTIFIED
- SHIMMING OF THE SADDLES MAY BE REQUIRED
- CENTER VESSEL ON 2 OR 3 SUPPORTS AT SPAN(S) "S".
- INCORRECT MANIFOLDING WILL CAUSE SEVERE LOCAL STRESS AROUND PORT AND MAY RESULT IN LEAKS AND PREMATURE FAILURE. TAKE EVERY PRECAUTION LISTED IN THE ENGINEERING PACKET OR USERS MANUAL.
- INTERNAL PERMEATE PRESSURE MUST NOT EXCEED 125 PSI.
- ASME SECTION X, 2010  
 RP CODE STAMP OPTIONAL
- SPECIFICATIONS SUBJECT TO CHANGE WITHOUT NOTICE



www.protec-arisawa.com

**PRO 8-150-EP**

APPROVED  
 AP  
 5/21/01  
 CHECKED  
 AP  
 5/21/01  
 DRAWN  
 AP  
 5/21/01

ECO	REVISED	DRAWING	REV
10119	4/28/11	101007	M

Shell Length Code	L inch (mm)	S Span in (mm)	Empty Weight lb (kg)
-1	61 (1549.40)	34 (863.60)	42 (19)
-1.5	81 (2057.40)	45 (1143.00)	51 (23)
-2	101 (2565.40)	56 (1422.40)	56 (25)
-3	141 (3581.40)	80 (2032.00)	70 (32)
-4	181 (4597.40)	104 (2641.60)	84 (38)
-5	221 (5613.40)	128 (3251.20)	98 (45)
-6	261 (6629.40)	150 (3810.00)	112 (51)
-7	301 (7645.40)	3 PTS.	126 (57)
-7.5	321 (8153.40)	3 PTS.	133 (60)
-8	341 (8661.40)	3 PTS.	140 (64)