

Design Pressure = 600 PSI @ 120 °F
 Min. Design Temperature = 20 °F @ 600 PSI
 Hydrotest Pressure = 660 PSI

600 PSI
 SIDE PORT

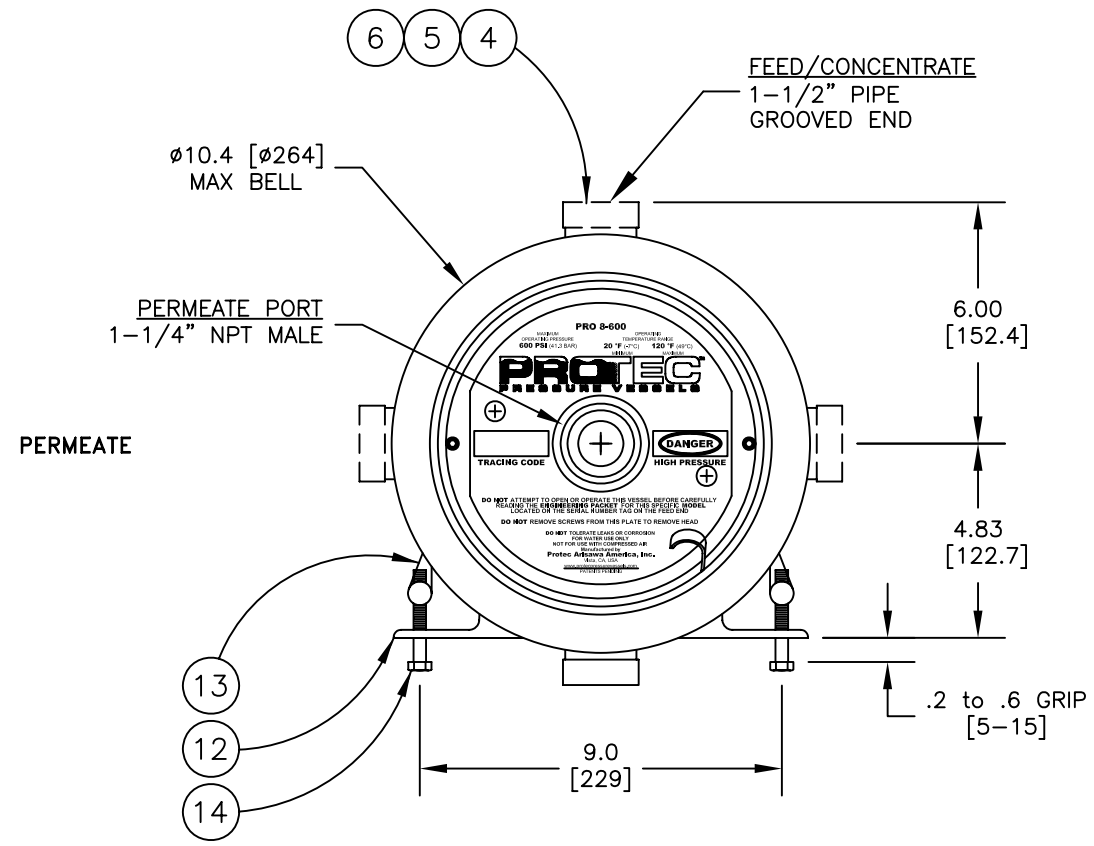
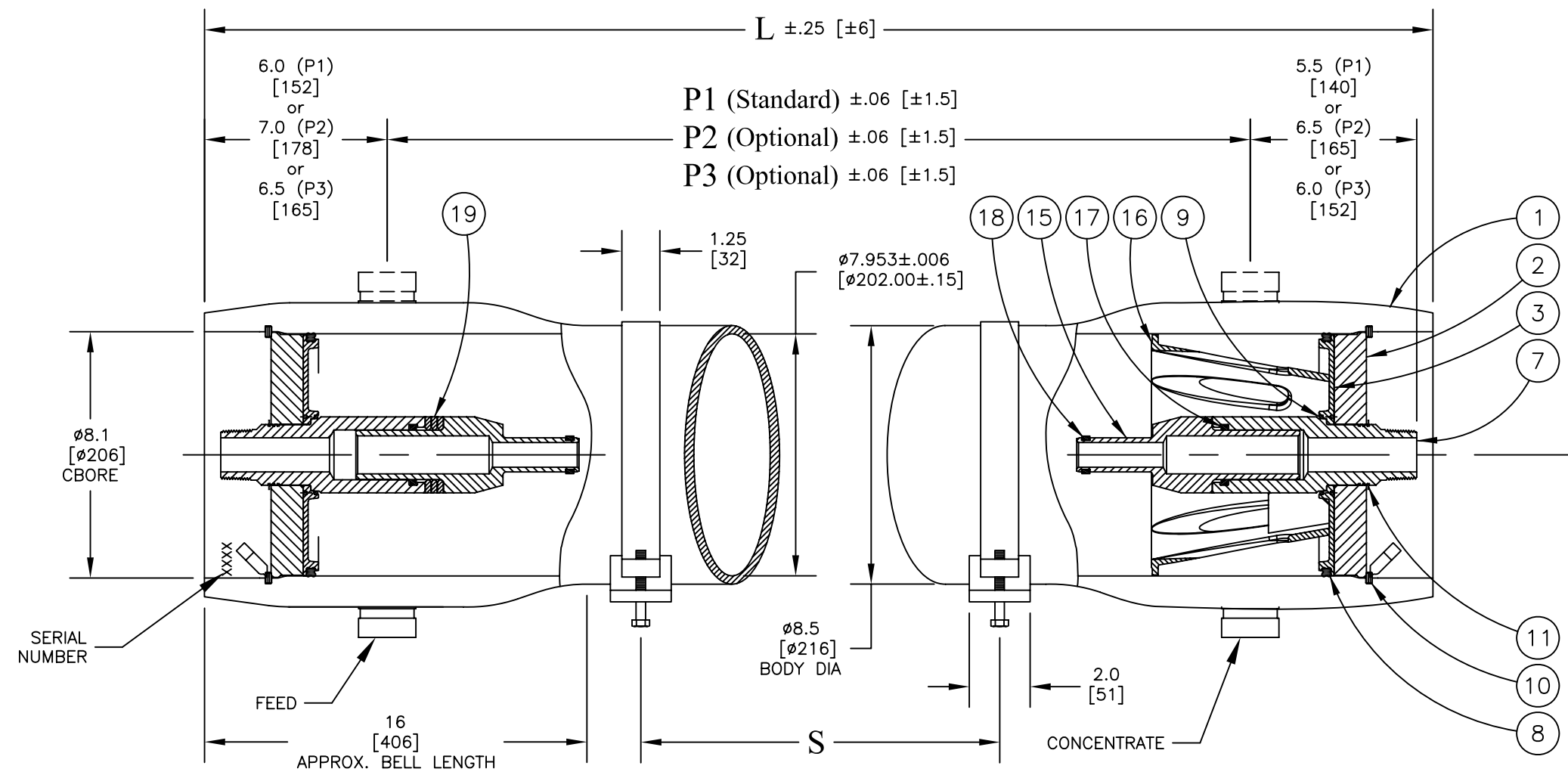

NOTE: STANDARD PARTS ARE SHOWN FOR REFERENCE ONLY
 CHECK ORIGINAL ORDER FOR ORDERING SPARE PARTS

Shell Length Code	L inch (mm)	P1 Standard inch (mm)	P2 Optional inch (mm)	P3 Optional inch (mm)	S Span in (mm)	Empty Weight lb (kg)
-1	59 [1498.60]	47 [1193.80]	45 [1143.00]	46 [1168.40]	1 @ 28 [711.20]	87 [40]
-1.5	79 [2006.60]	67 [1701.80]	65 [1651.00]	66 [1676.40]	1 @ 42 [1066.80]	103 [47]
-2	99 [2514.60]	87 [2209.80]	85 [2159.00]	86 [2184.40]	1 @ 56 [1422.40]	118 [54]
-3	139 [3530.60]	127 [3225.80]	125 [3175.00]	126 [3200.40]	1 @ 80 [2032.00]	150 [68]
-4	179 [4546.60]	167 [4241.80]	165 [4191.00]	166 [4216.40]	2 @ 64 [1625.60]	181 [82]
-5	219 [5562.60]	207 [5257.80]	205 [5207.00]	206 [5232.40]	2 @ 78 [1981.20]	212 [96]
-6	259 [6578.60]	247 [6273.80]	245 [6223.00]	246 [6248.40]	2 @ 92 [2336.80]	243 [110]
-7	299 [7594.60]	287 [7289.80]	285 [7239.00]	286 [7264.40]	2 @ 106 [2692.40]	274 [125]
-7.5	319 [8102.60]	307 [7797.80]	305 [7747.00]	306 [7772.40]	2 @ 114 [2895.60]	290 [132]
-8	339 [8610.60]	327 [8305.80]	325 [8255.00]	326 [8280.40]	2 @ 120 [3048.00]	305 [139]

ITEM	QTY	P/N	DESCRIPTION	MATERIAL
1	1	4080021	Shell	Filament Wound, Epoxy FRP
2	2	4080032	Bearing Plate	6061-T6 Aluminum, SB-221, Anodized
3	2	4080177-3	Sealing Plate	Noryl GFN2
4	2	4080257-1	Feed/Concentrate Port, 1-1/2", "D"	Stainless Steel, 316, SA-312
5	4	6121187	Retaining Ring, F/C Port, 1-1/2", "D"	Stainless Steel, 316, SA-479
6	2	6184604-N	O-Ring Seal, F/C Port, 1-1/2", "D"	Ethylene Propylene
7	2	4080309	Permeate Port	Noryl GFN2
8	2	6100442MK	Head Seal	Ethylene Propylene
9	2	6110229-N	Permeate Port Seal	Ethylene Propylene
10	2	4080320	Retaining Ring w/ Finger Pull	Stainless Steel, 316, SA-479
11	2	6121200	Retaining Ring, Permeate Port	Stainless Steel, 316
12	2*	4080174	Support Saddle	Thermoplastic Rubber
13	2	4080137	Strap Assembly	Stainless Steel, 316L
14	4	6150001	Strap Screw	Stainless Steel, 18-8
15	2	A/R	Adapter	Thermoplastic
16	1	4080165-1	Thrust Cone	PVC Thermoplastic
17	2	6110326-N	Adapter Seal	Ethylene Propylene
18	A/R	A/R	PWT Seal	Ethylene Propylene
19	3	4080062-4	Shim, Adapter	Noryl GFN2

*3 each with shell length -4 and longer

NOTES:
 DIMENSIONS IN INCHES (MM APPROX.)
 FOR REFERENCE ONLY, NOT FOR CONSTRUCTION UNLESS CERTIFIED
 SHIMMING OF THE SADDLES MAY BE REQUIRED
 CENTER VESSEL ON 2 OR 3 SUPPORTS AT SPAN(S) "S".
 INCORRECT MANIFOLDING WILL CAUSE SEVERE LOCAL STRESS AROUND PORT AND MAY RESULT IN LEAKS AND PREMATURE FAILURE. TAKE EVERY PRECAUTION LISTED IN THE ENGINEERING PACKET OR USERS MANUAL.
 INTERNAL PERMEATE PRESSURE MUST NOT EXCEED 125 PSI.
 ASME SECTION X, 2010
 RP CODE STAMP OPTIONAL
 SPECIFICATIONS SUBJECT TO CHANGE WITHOUT NOTICE



PRO 8-600-SP

APPROVED AP 6/25/01	ECO	REVISED 4/28/11	DRAWING 101004	REV R
CHECKED AP 6/25/01				
DRAWN AP 6/25/01	10119			